



PURY-P650YSJM-A

Standard R2 Series 26hp Outdoor Unit

R410A Heat Recovery

Many buildings require cooling in some areas and heating in others - even in adjacent rooms. The outstanding City Multi R2 system meets this requirement by distributing surplus heat from cooling operations (and vice versa) to rooms where it is needed. This efficiency can result in energy savings of up to 30% over conventional systems.



Pictures not to scale

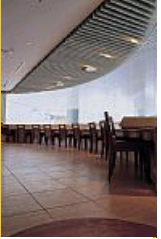

Product Details

PURY-P650YSJM-A	
Capacity (kW):	
Heating (Nominal)	81.5
Cooling (Nominal)	73.0
Heating (UK)	73.8
Cooling (UK)	67.2
Power Input (kW) Heating (Nominal)	20.47
Power Input (kW) Cooling (Nominal)	21.53
Power Input (kW) Heating (UK)	23.34
Power Input (kW) Cooling (UK)	13.56
Max No. of Connectable Indoor Units	50
Airflow(m ³ /min)	225 /185
Noise (dBA)	62.5
Width - mm	1220
Depth - mm	760
Height - mm	1710
Weight - kg	270 + 245
Electrical Supply	380-415v, 50Hz
Phase	3
Mains Cable No. Cores	4 + earth
Starting Current (A)	8
Running Current (A) - Heating	31.6
Running Current (A) - Cooling	33.2

Piping Restrictions

Total Piping Length (m)	800
Furthest Piping Length (m)	165
Between Outdoor and BC Controller - Length (m)	110
Between Indoor and Outdoor Units - Height (m)	50
Between Indoor and Indoor Units - Height (m)	15

Dimensions

PURY-P650YSJM-A

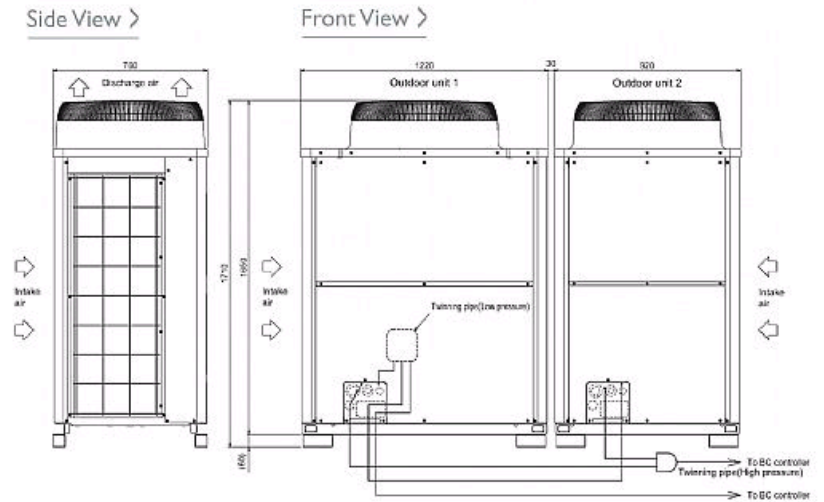

Telephone: 01707 282880

Email: air.conditioning@meuk.mee.com Website: <http://www.mitsubishielectric.co.uk/aircon>

Mitsubishi Electric reserves the right to make any variation in technical specification to the equipment described, or to withdraw or replace products without prior notification or public announcement.

Tel:
Fax:

